

REVISION HISTORY		
REV	DESCRIPTION	DATE
A	Issued for Approval	1/03/2023
0	Issued for Manufacture	28/03/2023
1	Update Model	11/04/2023
2	Change height, added stopper and shortened tube guide	26/05/2023
3	Changed Stopper added VPS-012	30/05/2023
4	Reverted height, added round plug	2/06/2023
5	Changed project and description name	12/06/2023
8	Added rubber grommet, VPS-014	27/06/2023

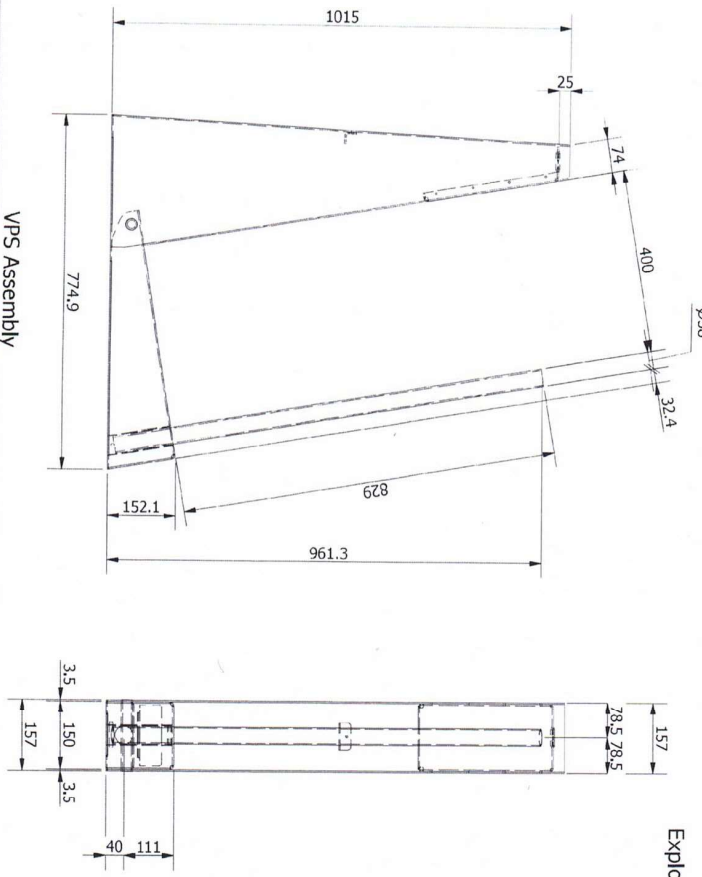

PARTS LIST			
ITEM	QTY	DESCRIPTION	STOCK NUMBER
1	1	Main Back Plt	VPS-001
2	1	Main Support Base	VPS-002
3	1	Top Support Plt	VPS-003
4	1	Base	VPS-004
5	1	Base Bottom Plt	VPS-005
6	1	Tube Guide	VPS-006
7	1	Base Board Stopper	VPS-007
8	1	Swivel Tube	VPS-008
9	1	Tube	VPS-009
10	1	8mm Rod	VPS-010
11	1	Stopper	VPS-011
12	1	Rubber Grommet	VPS-014

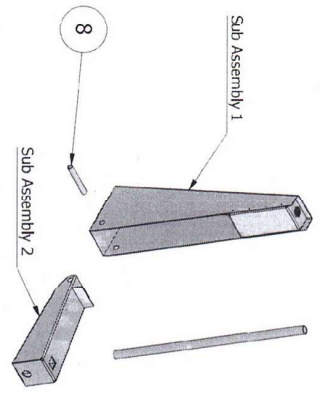
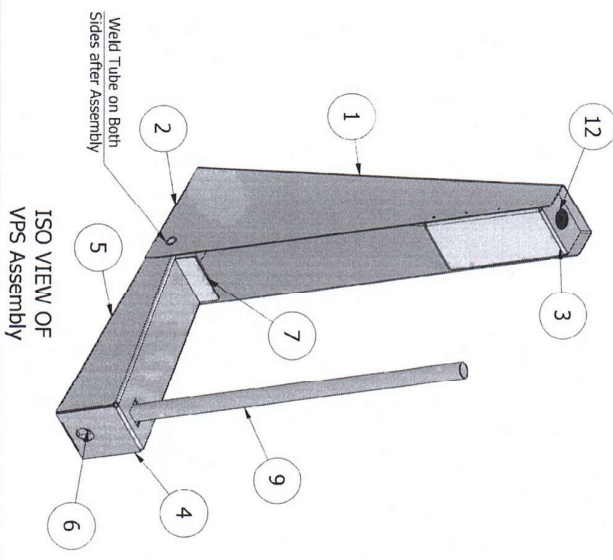

GENERAL NOTES:
 Material: Aluminium
 More info www.standit.co
 STANDIT is constructed from 3mm marine grade Aluminium sheet.
 All structural junctions are welded.
 Top support plate (item3) is pop riveted.
 Tested as per engineer's specifications.

PROJECT NAME: A Vertical Panel Storage (VPS) Device
 DRAWING TITLE: A Design for STAND IT
 DRAWN BY: Carl Koch (CAD)
 CHECKED BY: LT
 APPROVED BY: MH
 DATE: 1/03/2023

CLIENT NAME & ADDRESS:
 Matrixx Innovation Ltd
 Matrixx Innovation Ltd
 Auckland, Auckland
 New Zealand
 CONTACT NO: 021 415 551
 Email: matrixxinnovation.com

SRS GROUP
 SRS Group NZ Ltd
 2F Rothwell Ave
 Rosedale, 0632
 +64 9 953 0599
 www.srsgroup.co.nz

PROJECT NO: D2916
 SHEET NO: 1/8
 UNIT: --
 SHEET SIZE: A3
 SCALE: 1 : 10
 REVISION: 8
 DRAWING NO: D2916-Z-0001

THE CONTENTS AND COPYRIGHT OF THIS DRAWING REMAIN THE PROPERTY OF SRS GROUP NZ LTD.